



VEILUX



INDEX

I. Keyboard Overview	1
II. Technical Parameters	1
III. Keyboard Drawing	1
3.1 The Keyboard Connection	2
3.2 The Keyboard Connection with the Dome Camera	2
IV. Function Key	3
V Keyboard Parameters Setting	4
5.1 Keyboard Parameters Setting	4
5.1.1 Keyboard ID No Set	5
5.1.2 Keyboard Baud Rate Set	5
5.1.3 key-press Sound Set	6
5.1.4. Matching Resistance Set	6
5.1.5. Keyboard Communication Protocol set	6
5.1.6 Keyboard Test	7
5.1.7 Max Vice Control Number Set	7
5.1.8. Max Alarm Set	8
VI. The Intelligent Keyboard Operation Way	8
6.1 Keyboard Communication Address Set	9
6.2 The Keyboard Control for Dome Camera	9
6.3 Auto Scanning	9
6.4 Set Preset Position	10
6.5 View Preset Position	11
6.6 Preset Position Parameter Set for the Dome Camera	11
6.6.1 Preset Position Speed and Dwell Time Set	12
6.6.2 Pattern Tours Set	14
6.7 Guard Location Set	16
6.8 Guard Location Parameter Set	17
6.9 Dome Camera Menu Set	18
VII Auxiliary Function Set	18
7.1 Wash Brush Set	19
7.2 Heating Set	19
7.3 Auxiliary Switch 1 Set	19
7.4 Auxiliary Switch 2 Set	20
7.5 Proportion Joystick	21
IX. Exception Handles	22
X. The keyboard Key-press Function	23

I. Keyboard Overview

The keyboard is used for controlling the intelligent dome. The keyboard is the main device between operator and device in the monitoring system. It can be regarded as the main control keyboard and as the vice control keyboard.

1. Liquid Crystal Display The LCD display board is regarded as interface between operator and device. It is direct, convenient, easy to follow and conveys large amounts of information.
2. Proportion Joystick¹ (Options: PTZ control joystick and PT control joystick, Use this joystick to operate high-speed dome. It is easy to use with good handling and flexible maneuvering
3. The lock function of the keyboard can prevent unauthorized users to operate the keyboard.
4. Provide RS485 control output signal and also offer the standard RS232 control signal.

II. Intelligent Keyboard Technical Parameters

1. Communication baud rate:1200bps;2400bps;4800bps;9600bps
2. Protocol: PELCO_D, PELCO_P
3. Data Format: N,8,1
4. Power input: AC/DC 9V-12V
5. Max controlled dome camera:1024 ²
6. Power: 5W

III. Intelligent Keyboard Drawing

3.1 Intelligent Keyboard Connection

Insert one end of keyboard data line into keyboard A2,B2 on the right of its back panel..

Proportion Joystick: The speed of the joystick is a direct ratio to the running speed of the dome camera.

2. The keyboard can set up to 1024 sole addresses. However, it does not control 1024 dome cameras directly. The strength and weakness of the RS485 control signal determines the speed dome quantity. It can control up to 1024 VPTZ dome cameras through signal compensation devices. The RS485 can control 32

dome cameras at most if it has no signal compensation.

Wire Box Inner Function Picture

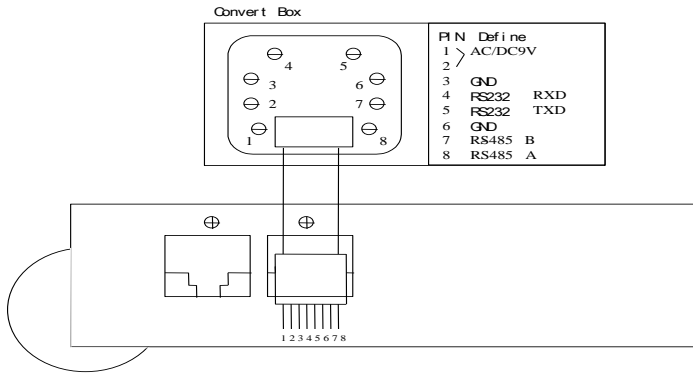

3.2 Keyboard Connection with Dome Camera

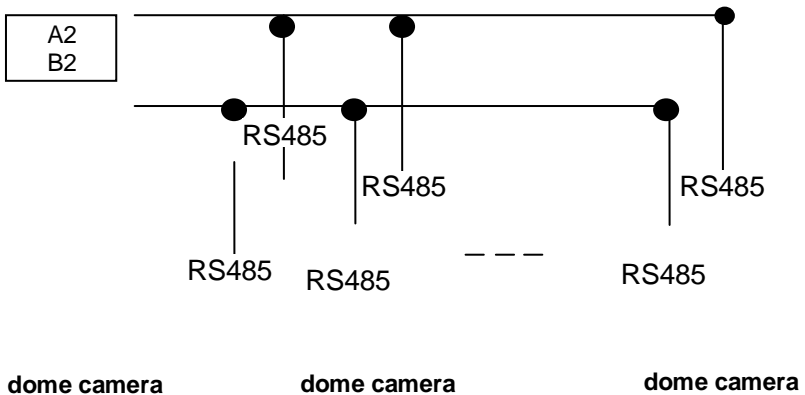

⚠ When dome camera is furthest away from the control keyboard, Please set switch of matching resistance as ON status.

3. R is on behalf of matching resistance. The farthest dome from the control center should be set as its matching resistance in order to minimize RS485 bus reflection and disturbance. The 8thbit of SW3 shows ON status which means the BUS matching resistance has been connected.

IV. Function Key

- Joystick: Control Dome Camera running: Up, down, Left, Right, Left-up, Left-down, Right-up, right-down, camera lens zoom in and zoom out
Keyboard joystick can't control Dome Camera lens zoom in and zoom out.
- Dome Camera Selection and Auto scanning Control
- Data Input, Clear and Confirmation
- Menu Turning, Exit and Preset Position Set
- Dome Camera Lens Control and Keyboard Lock and Unlock
- LCD Data Display

Function Key Explanation is As Below:

KEY	Function
0-9	Data key
Clear	Clear the inputted number on the DATA display area.
MON	matrix monitor selection
CAM	Dome Camera address selection
Enable	Alarm open set ⁴
Shift+ Enable	Alarm close set ⁴
Shift+Clear	Clear Alarm
Pan_A	Set the start point of dome camera auto scanning.
Pan_B	Set the end point of dome camera auto scanning.
Auto	Finish Dome Camera auto action/ select menu items down
Shift+ Auto	Adjust Dome Camera pattern tour function

Scan	Startup scanning group(model NO.1)
Shift+ Scan	Startup scanning group(model NO.2)
Call	Call Dome Camera preset position function

Shift+Call	Set Dome Camera preset position function
MPX	Clear Dome Camera preset position function/ select menu items up
MENU	Enter keyboard menu

Other key such as GRP, SEQ, NEXT, AREA, DVR, is designed for other terminal device.

Camera Lens control

Zoom in: Press <ZOOM in> key/ joystick make a veer rotation

Zoom out: Press <ZOOM out> key/ joystick make a restores rotation

Focusing Far: Press <FOCUS far> key

Focusing near Press <FOCUS near> key

IRIS open: Press <IRIS open> key

IRIS close: press<iris close> key

V. Keyboard Parameters Setting

⚠ The keyboard intelligent keyboard baud rate and communication protocol should be consistent with that of the dome camera.

5.1 Keyboard Parameters Set

Press "MENU" key enter Keyboard main menu

Then Press "MPX" or "Auto" key until LCD displays:



2) Keyboard setup

Press "Enter" key into keyboard set up menu. Press "MPX" or "Auto" key to enter the submenu. Press "EXIT" key to exit to the main menu.

5.1.1 Keyboard ID No Set

Press "Enter" key on keyboard screen "Keyboard setup" until LCD displays:



1. Cur. Keyboard ID: XX

→ Current keyboard ID No.

→ Input New ID No.

Input the number (0-16), press "Enter" key for confirmation. New ID will be in effect immediately.

ID: 00 Main Control Keyboard⁶, ID: 1-16 Vice Control Keyboard⁷.

⌵ The default keyboard ID number is No. 00. This is also the ID number for the Dome camera. Verify the keyboard ID, if the ID No, is not set correctly you will not be able to control the dome camera.

5. Keyboard ID is used to set multi controlling keyboards when a series of Cameras are required to be controlled. A group of speed domes can be supported by one main control keyboard and 16 vice control keyboards.

6. Main control keyboard: Its ID is 00. It enjoys priority when several keyboards are in control. Only one of several keyboards can be set as main control keyboard. ID must be sole, not repeated.

7. Vice control keyboard: ID is to be 01-16 keyboards

5.1.2 Keyboard Baud Rate Set

Press **"MPX"** or **"Auto"** key until LCD displays:

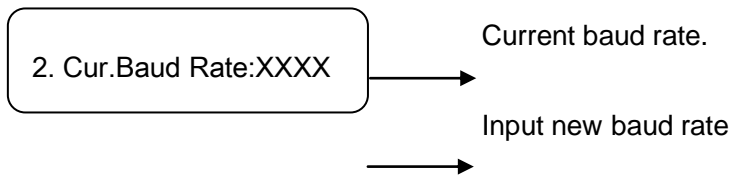

Optional baud rate: 9600, 4800, 2400, and 1200

Default baud rate: 9600bps.

Input your required baud rate in DATA area, and press "Enter" key for confirmation. New baud rate is in effect immediately.

5.1.3 Key-press Sound Set

Press "**MPX**" or "**Auto**" key until LCD displays:

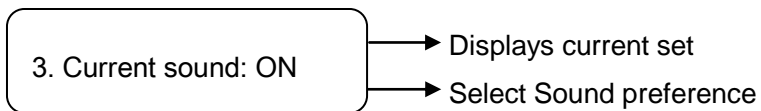

Press < F1/ON > key showing "ON"; turns on the sound function. Press "Enter" key for confirmation.

Press < F2/OFF > key showing "OFF"; turns off the sound function. Press "Enter" key for confirmation. The normal sound status is open.

5.1.4. Matching Resistance (150Ω) Set

Press "**MPX**" or "**Auto**" key three times until LCD displays:



Press < F1/ON > key showing "ON", this will place suited resistance between

RS485 D+ and D-,

Press < F2/OFF > key showing "OFF", this will separate suited resistance from

RS485 D+ and D-,

Press "Enter" key for confirmation. The normal status is open.

5.1.5. Keyboard Protocol Set

Press "**MPX**" or "**Auto**" key four times until LCD displays:

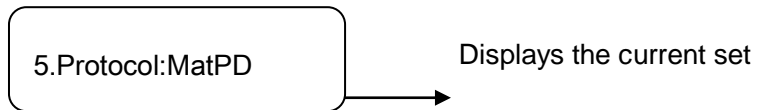

Press "1" key showing protocol, press "Enter" key for confirmation.

Press "2" key showing "PEL-D", PELCO-D⁹ protocol, press "ENTER" for confirmation.

-6-

Press "3" key showing "PEL-P", "PELCO-P" protocol, press "Enter" key for confirmation default protocol is the our PELCO-P Protocol.

8 Sometimes, matching resistance should be set at the control center in order to avoid reflection and disturbance from RS-485 communication signal and other signals.

9. PELCO-P, PELCO-D protocol: The keyboard can be used together with other high speed domes. When using a Camera, please adopt the “Vinte” protocol.

5.1.6 Keyboard Test

Press “**MPX**” or “**Auto**” key until LCD displays:

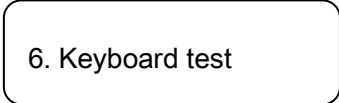

Press “Enter” key for confirmation, a blank screen will appear. Press any key except the <EXIT> key, the relative name will display on the screen.

Press <EXIT> to leave the testing status and return to the main menu.



If the keyboard test does not display the correct Keyboard protocol, the keyboard may be damaged.

5.1.7 Max Vice Control Number Set ¹⁰

Press “MPX” or “Auto” key until LCD displays:



Input number (00-16), Press “ Enter” key for confirmation.

⚠ If the keyboard is set as:01,02...16,it will be considered as the total

Vice control keyboard quantity separately.

5.1.8. Max Alarm Set ¹¹

Press “MPX” or “Auto” key until LCD displays:



Input number, the biggest alarm input terminal number is 239. Press “Enter” key for confirmation

⚠ If the keyboard is set as: 000,001,002...239,the total relative quantity for Alarm input terminal will be in operation.

¹⁰ When there are two or more than two keyboards in one system, please use

the main control keyboard to set the total desired vice keyboard quantity should be set(16 vice control keyboard at most). If the vice keyboard quantity are not set, the vice keyboards will not control camera dome. The number desired to input should be more than or equal to the total actual vice control keyboard quantity.

11 You should set the total alarm input terminal quantity for alarm dome camera if such dome camera is adopted. The number desired to input should be more than or equal to the total actual alarm input terminal quantity. One dome camera has 4 alarm input, i.e. 59 alarm dome camera can be connected with the keyboard at most.

VI. Intelligent Keyboard Operation

The startup interface is general operation menu after the keyboard is connected to the power supply.

LCD displays as follows:

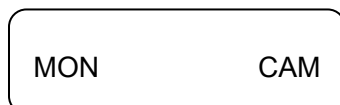

6.1 Keyboard Communication Address Set

Input any number within "1 ~ 1024"(Dome Camera address) in DATA area,

Press<CAM>key.

The relative number will display on CAM area.

6.2 Keyboard Control for Dome Camera

When Operating keyboard joystick in different directions, Dome Camera will do relative movement. The joystick excursion scope from center is direct ratio to running speed of Dome Camera.(0.4°/S-280°/S)

⌵ When the "DATA" column does not show "0",the "DATA" column displays the Address of the dome camera. When the "DATA" column shows "0", the "CAM" column displays the address Of the dome camera.

(Take "Pelco P" protocol for example to operate Dome Camera)

6.3 Auto Scanning (2 Points Scanning, 360° Scanning)

A . 2 Points Scanning ¹²

The operator can also run a simple point-to-point scan (also called back-and-forth scanning). To do this, set Preset Point A first (at the same time set the dwell¹³ time at Point A), and then set Present Point B (at the same time set the dwell time at Point B). Finally execute an outer command to scan between points A and B.

¹² 2 points scanning: It means scanning between two points. The speed is:

Grade1, Grade 2……Grade64 (from slow to fast)

Press “Clear” key on the keyboard DATA area to delete value on DATA column.

1. To set Point A. Move the joystick to the desired position.
2. In the Main Menu enter a dwell time for Point A. Example: If Dwell time is 2 seconds the keyboard displays:

3. Press “PAN A” key.

4. To set Point B, move the joystick to the desired position.

5. In the Main Menu enter a Dwell time for Point B.

6. Input the grade Speed (1-64) and Press "AUTO" key.

This will start up 2 points Scan

B . 360° Scanning ¹⁴

The Operator can also start an auto cruise scan. This scan will rotate 360° from the desired position.

Press "Clear" key on the keyboard DATA area to delete value on DATA column.

1. In the Main Menu, input desired cruise group No.

Example: Desired Group No. is 4 the keyboard displays:

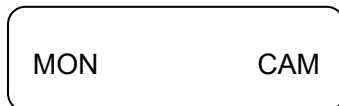

2. Press "Shift + Scan" key to place PTZ into cruise scanning.

OR

1. Move the joystick to desired position.

2. Input the running speed (1-64) and then input Shift + AUTO key.

⌵ Shake the keyboard joystick to stop auto scanning.

6.4 Set Preset Position

1. Press “Clear” key to clear the number in the data area.

2. Enter the Preset Position Number you wish to set. You can set up to 128 Preset

Positions.Ex. Set Preset Position No. 1, the keyboard displays:

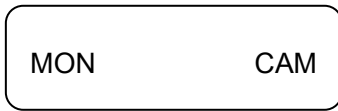

Displays the Preset Position Number
(1-128)

3. Adjust the camera to the desired position including location, camera zoom, focus and iris.

4. Press “Shift + Call” key for final confirmation.

¹³ Dwelling time: Can set dwelling time at one preset position: 1S,2S 60S

¹⁴ 360°scanning: 360°scanning at one preset position. Dome speed is: Grade1, Grade 2, . Grade 64 (from slow to fast)

6.5 View Preset Position

1. Press “Clear” key to clear the number in the data area.

2. Input the address of the dome in the Data area, press down<CAM> key and show it in DATA area.

3. Input the preset position you would like to view.

Example: View preset position No. 5



Displays the Preset Position Number (1-128)

4. Press "CALL" key. The dome will move to the Preset Position No.

⌵ After pressing "CALL" key, dome camera will nun to the present position you

Would like to view at Grade 64(280°/S) speed.

6.6 Preset Position Parameter Set for the Dome (Pelco P protocol has this function) ¹⁵

Press "MPX" or "Auto" key until LCD displays:

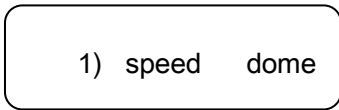

Press "Clear" key to delete previous data. Input required address code XXXX (1-1024) for control. Press "Enter" key for confirmation

Press "Enter" key into preset position set of dome camera.



The below menu is submenu. Press FUN into submenu after entering this main menu.

6.6.1 Preset Position Speed and Dwell Time Set

Dome Camera has the capacity to set up to 128 preset positions through the keyboard. It can set a running speed at each preset position from 0.4/s to 280/s (1-64 grades) and dwell time from (1-60 seconds).

Note: can rotate at low speeds and at fast speeds. Its speed can be divided into 64 grades. 1 is the lowest speed and 64 is the fastest speed. Press "Exit" key until the screen displays:

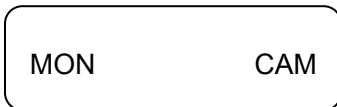

1. In the Current state, Press "MENU" key. The Keyboard displays:

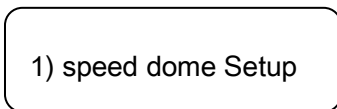

2. Enter the correct Speed Dome Unit and Press "Enter" key.

Example: Preset Position for Speed Dome 3. The Keyboard displays:

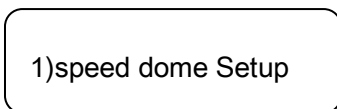

← Displays the Speed Dome Address (1-1024)

3. Now the Keyboard displays:

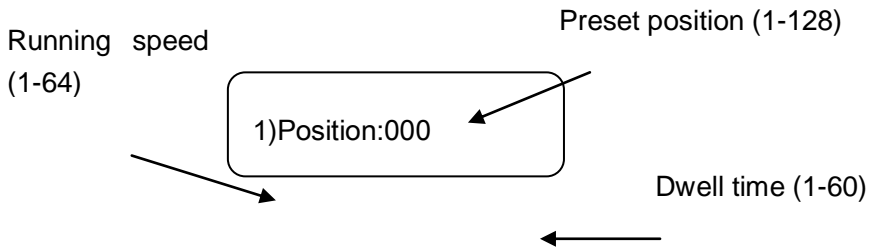

Press "F1/ON" the keyboard to move the cursor up and down

4. Press "Clear" key to delete previous data before programming to a new preset position.

5. Enter desired Preset Position and Press "Enter" key.

6. Press "F1/ON"key to get to Speed. Using the number keys enter the desired running speed.

7. Press "F1/ON"key to get to Time. Using the number keys enter the desired dwell time.

For example: Set the running speed of preset position No. 6 as Grade 64 (fastest speed), dwelling time is 5 seconds. Set the running speed of preset position No.2 as Grade 10, dwelling time is 10 seconds.

1. Press "MPX" or "Auto" key.
2. Press "Clear" key to clear the data.
3. Input 06 (Note: Setting the Preset Position No. 6) press "Enter" Key to Confirm.
4. Press "F1/ON" key to move the cursor to Speed:00←
5. Input 64, press "Enter" key
6. Press "F1/ON" key to move the cursor to Time:00←
7. Input 05, press "Enter" key
8. Press F1/ON to move the cursor back to 1.Position:001←
9. Press "Clear" to delete 0006
10. Input 02, press "Enter"key
11. Press "F1/ON" key to move the cursor to Speed:64←
12. Press "Clear" to delete 64
13. Input 10, press "Enter"key
14. Press t "F1/ON" key to move the cursor to Time:05←
15. Press "Clear" to delete 05

16.Input 10, press “Enter” key



Do not forget to press ENTER to confirm each Preset Position. Not doing so will result in lost information and the setting will not be effective.

6.6.2 Pattern Tours Set ¹⁶

The keyboard can set pattern tour groups for the speed dome camera. Before setting the Pattern Tours please set all preset positions in advance. If the preset positions are not set the pattern tour will default to the pattern tour parameter.

Note: can set 8 cruise groups.

1. Press “MENU” key, the keyboard displays:



1)speed dome Setup

Displays the Speed Dome Address (1-1024)



2. Enter the correct Speed Dome Unit and Press “Enter” key.

Example: Set Pattern Tour for Speed Dome Unit 02. The Keyboard displays:



1)speed dome Setup

Displays the Speed Dome Address (1-1024)



3. Press “MPX” or “Auto” key, until the keyboard displays:

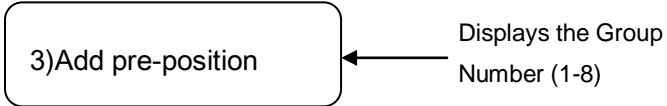

4. Input a Group number using the number keys, press “Enter” key, the keyboard

displays:



5. Input desired Pattern Tour for the Group. You can set up to 16 Preset

Positions in one Group.

Example: Desired pattern tour of 6 Preset Positions. The sequence is Preset

Position No.

1 – 2 – 3 – 4 – 5 – 6 –

The keyboard displays:

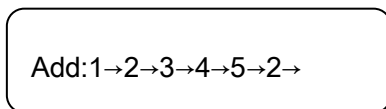

6. Press "Enter" key to confirm Pattern Tour.

Note: When completed, Press "F1/ON" to close and exit. To Start the Scan: In the Main Menu enter the Group Number and Press SCAN.

- This dome can set 8 cruise groups with a Max of 16 cruise points. Each group (1-128 points at any preset position).
- Set the preset position at each of the cruise groups
- Dwell time at each preset position can be customized at a different time (1-60 seconds).
- The speed to each preset position can be different (1-64 grades)
- Default cruise group will auto scan by starting at present position point No. 1 to preset position point No. 16.

¹⁶ Pattern tours: Layout different preset position for Dome Camera as one group, make the camera scan as set route in advance. The running speed and dwell time of each preset position can be programmed.

Two pattern tours styles can be used:

A .To-and-from Scanning

1-2-.....-16-1-2-.....-16-1-..... Make an auto circle scanning by points.

Press “EXIT” key and exit to default status of the keyboard. Input cruise Number adjust key SCAN into to-and-from scanning (as the above route)

B. Cruise Scanning

1-2.....15-16-15.....-2-1-2.....-15-16-15.....Make an auto cruise scanning Press “EXIT” key and exit to default status of the keyboard. Then input cruise group No and then input Shift + Scan. Into cruise scanning (as the above route).



If a point is not set or is deleted after being set, there will not be any scanning to these points.

Select:  Add the preset position to cruise

Press “Enter” key for confirmation after adding a preset position. Press “F2/OFF” key exit when setting is finished. Please set the preset position parameter before setting its pattern tours. If not setting dome preset position, Dome Camera will

operate default preset position parameter when it runs its pattern tours.

6.7 Guard Location Set

The guard location is an important position that the camera will come back to automatically when there is no operation for a defined period. The user can set a guard location and control the waiting time to the guard location, starting and stopping (1-255S) before allowing the camera to return to the guard location. Use the keyboard to set the guard location and its waiting time.

Turning the Guard Location On/Off and Setting delay time to Guard Location

1. To set the guard location to start or stop (The keyboard recognizes this action as a Switch):

ON: Start OFF: Stop

Press "F1/ON" key ON Startup the guard location

Press "F2/OFF" key OFF Stop guard location

Example: Press "F1/ON" key ON to start up guard location. Dome will rotate to set position within XX seconds.

2. In the Main Menu screen, press "**MPX**" or "**Auto**" key, until key once, LCD

displays:

1) speed dome Setup

← Displays Current Speed
dome address

3. Press "Enter" key to Confirm.

4. Press "**MPX**" or "**Auto**" key, until LCD displays:

4) Watch Position

5. Input the desired waiting time using the number keys:

Example: After inputting time: 05, press "Enter" key.

4) Watch Position

6.8 Guard Location Parameter Set

1. When the keyboard is under default (Main Menu) status, press "MPX" or "Auto" key, until the keyboard displays:

1) speed dome Setup

2. Press "Enter" key to confirm.

3. Press "**MPX**" or "**Auto**" key, until the keyboard displays:

3.Press Enter Key To

4. Move the joystick/rocker to the target position you would like to set as the Guard Location.

5. Press “Enter” key to set the Guard Location.

The position is set as the guard location.

6.9 Intelligent Keyboard Menu Set for

Press “MPX” or “Auto” key, until keyboard will display:

Press “MPX” or “Auto” key

5)dome menu

Press enter to menu

5 Dome menu

Data:0000: 

Data:0000 → Press “Clear” key to delete previous data, input required

address of (1-1024),press “Enter” key.

Operating menu see below for reference:

Operating Key	Function
Enter	Enter
Login	Exit function
MPX	Dome menu cursor up
Auto	Dome menu cursor down
Call	Dome menu cursor right
Scan	Dome menu cursor left
Pan_A	Select
DVR	Keyboard function menu exit to upper menu

Dome camera menu set should consult Dome Camera manual.

VII. Auxiliary Function Set

⚠ The auxiliary function is used with other Pelco P products. It is not used with the Dome camera.

7.1 Wash Brush Set ¹⁷

Press "**MPX**" or "**Auto**" key until LCD display as below:

3) Wash

Number: 0001 OFF→Set "Wash Brush" open by pressing down "F1/ON" key,

Set "Wash Brush" close by pressing down "F2/OFF" key.

7.2 Heating Set ¹⁸

Press "**MPX**" or "**Auto**" key until LCD display as below:

4) Warm

Number: 0001 OFF→Set "Heating" open by pressing down "F1/ON" key, Set

"Heating" close by pressing down "F2/OFF" key.

7.3 Auxiliary Switch 1 Set

Press "**MPX**" or "**Auto**" key until LCD display as below:

5) Auxiliary#1

Number: 0001 OFF→Set "Auxiliary Switch 1" open by pressing down "F1/ON

"key, Set "Auxiliary Switch 1" close by pressing down "F2/OFF" key.

¹⁷ This function is used for the frontal terminal device with the wash brush function only.

18. The fan and heater in the speed dome camera is always under auto temperature control status. This function will auto start when the temperature reaches higher point or lower point.

7.4 Auxiliary Switch 2 Set

Press **"MPX" or "Auto" key** until LCD display as below:

6) Auxiliary#2

Number:0001 OFF→Set "Auxiliary Switch 2" open by pressing down "F1/ON

"key, Set "Auxiliary Switch 2" close by pressing down "F2/OFF "key.

7.5 Proportion Joystick

⚠ This function has been set well before the keyboard leaves the factory. The speed of the Joystick is a direct ratio the running speed of the dome. If it is not a direct ratio; reset the keyboard joystick parameter.

Press "MPX" or "Auto" key until LCD displays:

8) Joy Stick Set

Tilt:000 Pan:000→ Display Joystick value(Up, Down, Left, Right)

8.1 Set Joystick middle value (dwelling time)

When stop on the middle part, set joystick middle status by pressing "AREA" key.

8.2 Set joystick up limit value

Move the joystick to top (up), set its upper limit value by pressing "SEQ" key

8.3 Set joystick down limit value

Move the joystick to bottom, set its lower limit value by pressing "MON" key

8.4 Set joystick left limit value

Move the joystick to left side, set its left limit value by pressing "GRP" key

8.5 Set joystick right limit value

Move the joystick to right side, set its right limit value by pressing "Next" key

8.6 Set joystick restores limit value (limited for PTZ keyboard

–only)Move the middle pillar of joystick to the bottom extrorsely, set its restores limit value by pressing "Pan_A" key

8.7 Set joystick veering limit value (limited for PTZ keyboard –only)

Move the middle pillar of joystick to the bottom veer; set its veering limit value by pressing "Pan_B" key

See below chart for setting reference.

Operating Key	Function
Pan_A	Set joystick restores limit value
Pan_B	Set joystick veer limit value
GRP	Set joystick left limit value
Next	Set joystick right limit value
SEQ	Set joystick up limit value
MON	Set joystick down limit value
AREA	Set Joystick middle value

IX. Exception Handles

Exception phenomena	Possible reason	Relative solution
<p>No display on the screen when the power on</p>	<ol style="list-style-type: none"> 1. Power supply is not connected properly 2. Watt is not enough 	<ol style="list-style-type: none"> 1. Check connection of power line 2. See if power supply is AC/DC 9V-12V
<p>No way to control designated dome or high speed dome</p>	<ol style="list-style-type: none"> 1. Protocol is not correct 2. Baud rate is not correct 3. Controlled address is not correct 4. the polarity of control line is not correct 	<ol style="list-style-type: none"> 1. Check if the keyboard protocol accords with that of dome or high-speed ball or not. 2. Check if the baud rate of the keyboard accord with that of dome or high-speed ball or not. 3. The number in CAM or DATA area can't accord

		with the object address
No Bi sound when pressing key	Key-press sound is closed	Start up key-press sound in the keyboard set
Other phenomena		Back to manufacturer for maintenance

⚠ When using the keyboard to control other dome cameras, keep the keyboard setting (Baud rate, protocol, address) consistent with the dome camera. Some dome camera addresses have a ± 1 difference the keyboard does not.

X. Key-press Function

Protocol Operating

Key	Function
Call	Adjust preset position
Shift + Call	Set preset position
Pan -A	Limited Site A
Shift_ Pan -A	Limited B
Auto	Line Scan (scanning between two points)
Shift _Auto	Panel Scanning (Mode Scanning)
Scan	Start up the perambulate group
Shift + Scan	Start up intercourse perambulate group
CAM	LCD show CAM area address

PELCO_D Protocol Operating

Key	Function
-----	----------

Call	Adjust preset position
Shift + Call	Set preset position
MPX	Clear preset position