

V-ARMOR SERIES SVEX-610-2M20X-ZN

Explosion Proof Integrated Camera



Description

SVEX-610-2M20X-ZN is a Veilux designed classic explosion-proof integrated camera, which is integrated by explosion proof camera (housing), pan tilt decoder and wiper, it makes install and debug on site convenient. The explosion proof camera can apply for Zone 1 and Zone 2 hazardous areas that explosive mixture of group IIA, IIB, IIC, T1~T6 gases, vapors and air may exist, Zone 21 and Zone 22 hazardous areas that explosive dust may exist. It's applicable for refining and chemical industry, oil extraction, gas production, fireworks production, grain production and storage, petrol station etc.

Description

- ATEX, IECEx Approved;
- Applicable for Gas Zone 1, Zone 2,
- (Class II A, IIB, IIC, T1-T6 group)
- Dust Zone 21, 22.
- Certified for the latest standards IEC/EN60079 (2014)
- Stainless steel 304 or 316L enclosure
- Surface optional electro-polished or painting
- Weather Proof IP68(1.2m/45min)
- Wide voltage input: AC100-240V or AC24V
- Strong tempered glass, fit for hydrofluoric acid area
- Intelligent window defroster design
- Auto temperature adjust kit for aggressive area
- High precision wiper , support user-defined
- Auto temperature adjust kit for aggressive area
- Symmetrical balancing design
- Intelligent long focal speed limit, fit for long distance monitoring

Specifications

CERTIFICATE	
Certificate Mark	2G Ex db IIC T6 Gb, 2D Ex tb IIC T80°C Db
Certificate No	Presafe 17 ATEX 11328X, IECEx PRE 18.0030X
Standards	IEC/EN60079, ONVIF, CGI, GB/T28181, PISA
MECHANICAL	
Housing	Stainless steel 304/316L
IP	IP68
Cable thread hole	1pcs M25×1.5
Sun-shield	yes
ELECTRICAL	
Voltage	100~240V AC or 24V AC / AC80~265V
Power	50W/70W
Surge Protect	Optional
Optical Fiber Output	Optional
AMBIENT	
Ambient Temperature	-40°C~ +60°C
Air Pressure	80kPa~120kPa
Relative Humidity	≤95%RH(+25°C)
PAN & TILT	
Horizontal	Continuous 360°
Horizontal Speed	0.1~45°/s
Vertical	-90°~90°
Cruise Scan	Support
Keep Watch	Support
Preset	64/128/255/300
Resume Function	Support
Auto Cruise	Support
Auto Scan	Support
ALARM	
Alarm Input	2-channel/ 7-channel
Alarm Output	1-channel, action with alarm
Intelligent Alarm	Audio detective, move detective, video shield, network inte
CAMERA	
Image Sensor	1/2.8" Progressive Scan CMOS
Lens	20X ,4.7-94mm
Aperture Range	F1.6-F3.5
Angle of View	61.4-29 degree (wide -tele)
Min Illumination	Color: 0.04Lux @ (F1.6, AGC ON) B/W: 0.004Lux @ (F1.6, AGC ON)
Day & Night	ICR
S/N Ratio	>50dB (AGC off)
Gain	Auto/Manual
CAMERA (CONTINUED)	
Digital Zoom	12X

V-ARMOR SERIES SVEX-610-2M20X-ZN

Explosion Proof Integrated Camera



White Balance	Auto 1/Auto 2/Indoor/Outdoor/Manual/Sodium Lamp/Fluorescent Lamp
WDR	ON/OFF, 15 levels adjustable
DNR	3D DNR
BLC	ON/OFF
Image setting	Zoom camera module function can be adjustable by client software or web browser
GENERAL	
Cable	Integrated cable
Dimensions	295 x 390 x 420 (mm)
Weight	30Kg
Mounted	wall, pole

Essential Accessories



M1-Mounting bracket (long) with half pan/tilt

Optional Accessories



SVEX-JXD assist equipments of explosion proof television and communication system.

Dimensions

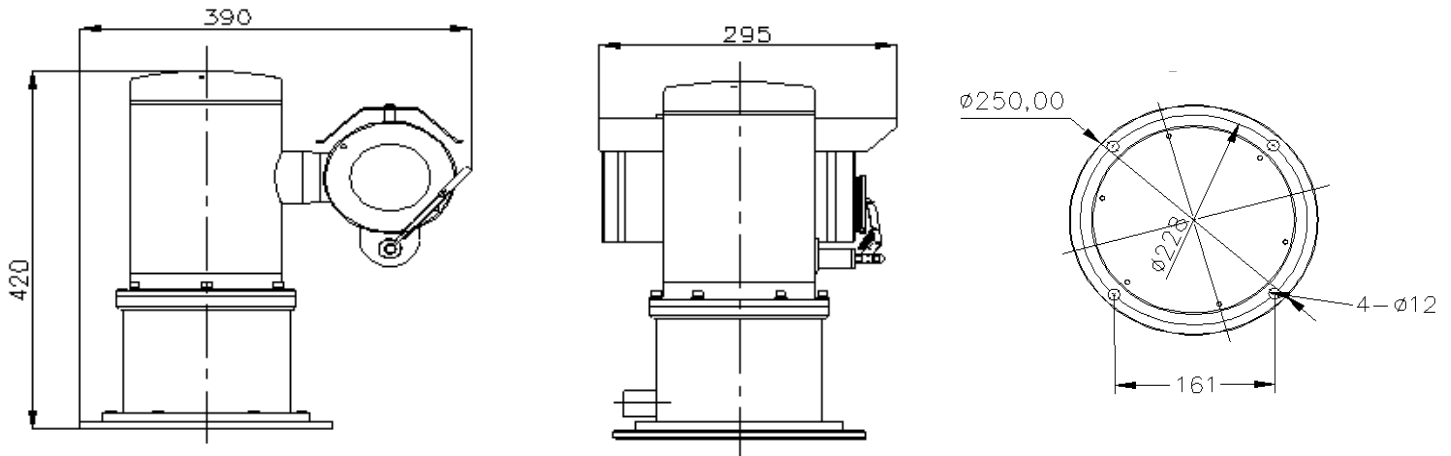

Units in mm