

V-ARMOR SERIES

SVEX-HIR7-Thermal-2M30X-XXXX-ZN



EXPLOSION PROOF/CORROSION PROOF POSITIONING UNIT WITH BUILT-IN DAY/NIGHT AND THERMAL CAMERAS



Description

SVEX-HIR7-Thermal-2M30X-XXXX-ZN stainless steel camera housing has been designed to protect cameras installed in highly aggressive area. Available 316L grade housing for more aggressive area, like marine, chemical factory, island, ocean shipping, sewage works.

SVEX-HIR7-Thermal-2M30X-XXXX-ZN adopts stepping motor and worn gear motor. Auto patrol, mechanical self lock, telephoto speed limit. The sun-shield protects the housing from the sunlight, from heat and dirt. With pan and tilt, 360° auto tracking, transmission speed 0.1~45°/s. With wiper system, and tempered glass front window for visible light. IR version for thermal imaging cameras available.

Features

- 304/316L Stainless steel construction
- Highest protection: IP68
- Double ex-proof marking: EXd & DIP
- Wide voltage: AC100-240V
- Stepping motor & worn gear motor
- Intelligent telephoto speed limits
- 360° Horizontal Auto tracking
- ±90° Vertical rotating
- 128 points patrol preset
- Ge glass for thermal imaging cameras available

Specifications

CERTIFICATE	
Certificate Mark	ExdIIC T6 Gb/Ex tD A21 IP68 T80°C
Certificate No	CNEx:18.4278X
Standards	Q32042ZAF047-2018
MECHANICAL	
Enclosure material	Stainless steel 304/316L
Surface finish	Electro-polished or corrosion resistant paint finish
Ingress protection	IP68
Threaded hole	1 set of G3/4 or M25*1.5 cable threaded entry
Window	Tempered glass for visible light Germanium with AR/DLC coating for thermal vision
Auto Tracking	Horizontal: 0~360° continuous, Vertical~±90°
Rotation Speed	0~45°/second
Optional	Integrated wiper system
Net Weight	26.4Kg
Package Size	501*295*366mm
ENVIRONMENT	
Mount	On wall or pole, Indoor/ outdoor
Operating Temperature	-25°C+60°C Optional-50°C~+60°C
Air Pressure	80KPa~106KPa
Relative Humidity	≤95%(+25)
AMBIENT	
Working voltage	AC85~265V, AC24V
Electric current	≤500mA
Power	<100W
Communication protocol	TCP/IP/PELCO-D/PELCO-P, other
Communication rate	2400~19200bps (adjustable)
Output mode	AV/ RJ45
Preset	128 points
DAY & NIGHT NETWORK CAMERA	
Image Device	1/2.8" Progressive Scan CMOS
Effective Pixels/Resolution	50HZ:25fps(1920x1080) 60HZ:30fps(1920x1080) 50HZ:25fps(1280x720) 60HZ:30fps(1280x720)
Optical Zoom	30X, 4.5-135mm
Digital Zoom	12X
Aperture Range	F1.6-F4.4
Angle Of View	65.1-2.34 degree (wide -tele)
Min. Working Distance	10mm-1500mm(wide-tele)
Zoom Speed	Approx 3s (optical, wide-tele)
Day & Night	ICR
Focus Mode	Auto/manual/one touch
Day & Night Mode	Auto/color/BW
Shutter Time	1/1sec-1/30,000 s
White Balance	Auto 1/Auto 2/Indoor/Outdoor/Manual/Sodium Lamp/Fluorescent Lamp
BLC	ON/OFF

V-ARMOR SERIES

SVEX-HIR7-Thermal-2M30X-XXXX-ZN



EXPLOSION PROOF/CORROSION PROOF POSITIONING UNIT WITH BUILT-IN DAY/NIGHT AND THERMAL CAMERAS

Exposure Compensation	10 levels adjustable
Gain	16 levels adjustable
Gain Limitation	16 levels adjustable
DNR	3D DNR
Mirror	Support
Digital WDR	ON/OFF, 15 levels adjustable
Imaging Setting	Saturation, brightness, contrast, sharpness adjustable
Video Compression	H.264 main profile/MJPEG
Video Bit Rate	32kbps-16mbps
Audio Compression	G.722.1/G.711-a law/G.711-u law/MP2L2/G.726
Imaging Setting	Zoom camera module function can be adjustable by client software ore web browser
Alarm	Motion detection, tampering alarm, storage full, storage exception
Protocol	TCP/IP, HTTP, DHCP, DDNS, RTP, RTSP, PPPoE, SMTp, NTP, UPnP, SNMP, FTP, 802.1*, QoS, HTTPS, IPv6(SIP, SRTP optional)
Standard	ONVIF, PSIA, CGI, ISAPI
Communication Interface	1 RJ45 10M/100M self-adaptive Ethernet interface, 1 RS-485.
Video Output	Dual core 1Vp-p Composite Output (75Ω□)
Lens value	Distance: 10mm-1500mm(Wide-Tele) Angle: 58.3-3.2 degree(Wide-Tele)
S/N ratio	More than 52dB
Minimum illumination	Color: 0.05Lux @ (F1.6, AGC ON) B/W: 0.01Lux @ (F1.6, AGC ON)

THERMAL VERSION			
Model	Resolution	Lens	Size (lens not included)
640	640*512 pixel	7.5mm, 9mm, 13mm, 19mm, 25m, 35mm, 50mm	45*45*45mm
336	336*256 pixel		
Detector	17μm VOx FPA pixels for greater image detail in Tau 2 640&336		
High sensitivity	<50mK @ f/ 1.0		

THERMAL VERSION - 640, 336		
	Person (Detective/recognition/identification)	Vehicle (Detective/recognition/identification)
Lens 7.5mm	210/52/26m	580/150/58m
Lens 9mm	250/63/31m	720/175/88m
Lens 13mm	390/95/47m	1080/275/140m
Lens 19mm	570/144/72m	1550/400/200m
Lens 25mm	820/210/104m	2200/580/290m
Lens 35mm	1140/280/142m	3000/800/200m
Lens 50mm	1500/380/190m	3900/1060/540m

Accessories



SVEX-HIR-WM Wall Bracket



SVEX-JXD - Junction Box.



FLEXIBILITY TUBE

Dimensions

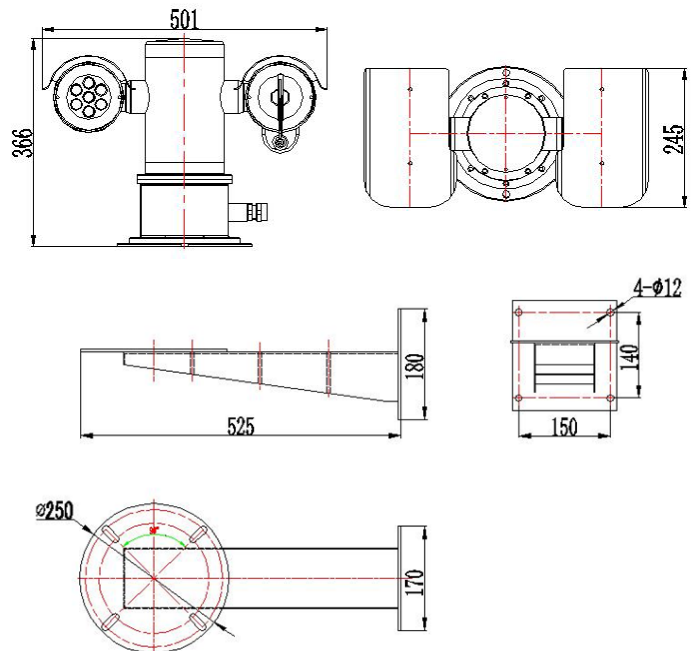

Units in mm