

# V-ARMOR SERIES SVEX-T100D-2M30X

Explosion-proof with IR light, wiper and 2MP 30X camera



## Overview

The explosion proof camera can apply for Zone 1 and Zone 2 hazardous areas that explosive mixture of group IIA, IIB, IIC, T1~T6 gases, vapors and air may exist, Zone 21 and Zone 22 hazardous areas that explosive dust may exist. It's applicable for refining and chemical industry, oil extraction, gas production, fire-works production, grain production and storage, petrol station and so on.

## Features

- ATEX, IECEx Certified;
- Applicable for Gas Zone 1, Zone 2, Class II A, IIB, IIC, T1~T6 group), Dust Zone 21, 22.
- Certified for the latest standards IEC/EN60079
- Stainless steel 304 or 316L enclosure
- Surface optional electro-polished or painting
- Weather Proof IP68(2m/2h)
- Wide voltage input: AC100-240V or AC24V or DC24V or PoE++
- Strong tempered glass, fit for hydrofluoric acid area
- Intelligent window defroster design
- Equipped with infrared light for night vision
- Equipped with wiper to keep window clean
- Auto temperature adjust kit for aggressive area
- High precision wiper, support user-defined
- Fit for various brand cameras
- Wall, pole, ceiling or corner mounted way

## Specifications

EX-PROOF MARKING	
<b>Certificate Mark</b>	Ex II 2G Ex db op is IIC T6 Gb Ex2D Ex tb op is IIC T80 °C Db
<b>Certificate</b>	ATEX: Presafe 20 ATEX 45644X, IECEX: IECEX PRE20.0042X
MECHANICAL	
<b>Housing</b>	Stainless steel 304 or 316L
<b>IP</b>	IP68 (2m/2h)
<b>Cable Thread Hole</b>	2pcs M25*1.5(standard) or M27*1.25
<b>Sun-Shield</b>	Optional
<b>Wiper</b>	Included
ELECTRICAL	
<b>Voltage</b>	AC100V~AC240V or DC24V or AC24V or POE++ (IEEE 802.3bt)
<b>Power consumption</b>	≤36W
<b>Surge Protect</b>	Optional, TVS6000V surge protect
<b>Optical Fiber output</b>	multi-mode single fiber or single mode single fibre Tx1310, Rx1550nm, FC connector
<b>Optical Video signal</b>	1-way video output
<b>Optional network signal</b>	RJ45
<b>Optical Audio</b>	1-way input, 1-way output
<b>Optical Alarm</b>	2-way alarm input, 1-way alarm output
<b>Address code:</b>	0/1
<b>Trail cable</b>	2m integrated cable Option 1: power+CAT Option 2: power+RS485+coaxial cable Option 3: power+CAT+audio+alarm+RS485+coaxial cable Option 4: power+CAT+audio+alarm+fiber cable
AMBIENT	
<b>Ambient temperature</b>	-40°C to +60°C
<b>Air pressure</b>	80Kpa to 110Kpa
<b>Relative Humidity</b>	≤95% (no condensation)
LIGHTS	
<b>Lights</b>	100m night vision(single light) 200m night vision (double lights)
<b>Light Wave Length</b>	850nm
<b>Lights Control</b>	Auto turn on/ off ,sync with camera day and night
<b>Type</b>	2MP 30X optical zoom camera
<b>Sensor</b>	1/2.8inch, 2.0 megapixel, progressive scan, CMOS
<b>Lens</b>	4.3-129mm, 30X optical
<b>Zoom</b>	automatic focusing and motorized zoom lens
<b>Iris</b>	Auto manual: F1.5~F3.4
<b>Shutter</b>	Auto/manual, shutter time: 1/6~1/8000s
<b>WDR</b>	120dB
<b>Day&amp;Night</b>	IR-cut filter with auto switch (ICR)
<b>Video Compression</b>	H.265, H.264
<b>Frame Rate</b>	1080P (1920x1080) Max 60fps
<b>Video Stream</b>	Three stream

# V-ARMOR SERIES SVEX-T100D-2M30X

Explosion-proof with IR light, wiper and 2MP 30X camera



<b>OSD</b>	Time OSD, customized OSD
<b>Motion Detection</b>	Supported
<b>Privacy Mask</b>	support
<b>Edge Storage</b>	Support Micro SD, up to 128GB
<b>Network Storage</b>	Dual-way iSCSI block storage
<b>Protocols</b>	L2TP, IPv4, IGMP, ICMP, ARP, TCP, UDP, DHCP, PPPoE, RP, RTSP, DNS, DDNS, NTP, FTP, UPnP, HTTP, SNMP, SI
<b>Compatible Integration</b>	ONVIF2.4, GB/T28181
<b>Digital Zoom</b>	16x
<b>GENERAL</b>	
<b>Wiper system</b>	Control by RS485
<b>Sunshade</b>	Optional
<b>Cable</b>	Integrated cable
<b>Size (LxWxH)</b>	523 x 297 x 221 (mm)
<b>Net Weight</b>	15.5 kg
<b>Compatible Mounts</b>	Wall, Pole, Corner

## Dimensions

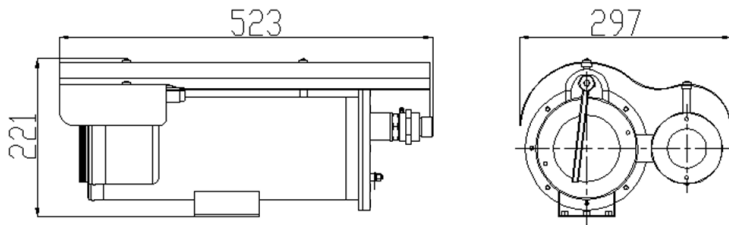

## Pole Mount Adapter

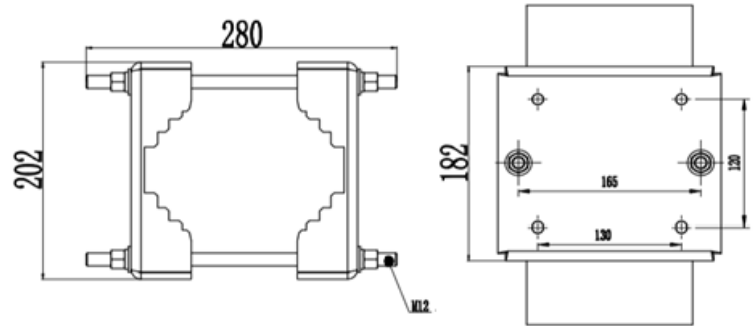

## Corner Bracket

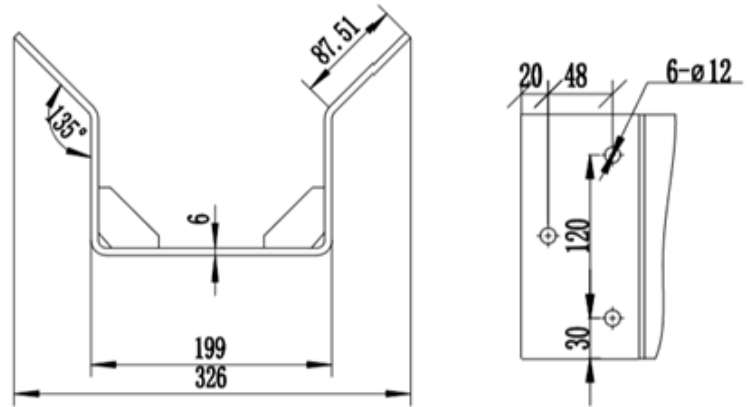

## Wall Bracket

